

Technical data sheet for

H10T-FS HOLDING CABINET - FULL SIZE

10 Tray Electric Holding Cabinet TOUCH SCREEN CONTROL



STANDARD FEATURES

- Designed for individual use or system installed with Turbofan E32T Convection Ovens
- 10 Full size 460mm x 660mm / 18" x 26" sheet pan capacity
- 74mm tray spacing
- Compact 735mm width
- 220-240V plug-in 13A cordset fitted
- 1900W cabinet heating
- Full double skin construction
- Touch Screen Control
- Icon driven program menu
- Individual shelf timers
- USB port for program/icon updating
- Electronic temperature control
- Continuous door seal
- Low velocity circulation fan system
- Dual halogen cabinet interior lamps
- Cabinet drain to condensate pan
- 4 dia. 76mm castors with 2 front castors with wheel and swivel lock, 2 rigid rear castors
- 100% recyclable packaging



H10T-FS

Unit shall be a Moffat electrically heated Turbofan Holding Cabinet. NSF4 listed. The holding cabinet shall have double skin construction with stainless steel interior and exterior sides, front and top. Door shall be side hinged. Unit shall have capacity for 10 full size 10 Full size 460mm x 660mm / 18" x 26" sheet pans. A single speed fan shall gently and evenly circulate air around the cabinet. Cabinet shall be controlled by a 5.7" Touch Screen control with individual shelf timers and cabinet temperature control. Holding cabinet shall be mounted on castors, with two rigid castors at rear and two castors, swivel and wheel lock at front. Holding Cabinet shall operate independently or in conjunction with Moffat Turbofan E32T Convection Oven. Holding Cabinet shall be fitted with a 13A cordset. Unit shall be supplied in 100% recyclable shipping packaging.

H10T-FS 10 Tray Electric Full Size Holding Cabinet TOUCH SCREEN CONTROL

CONSTRUCTION

304 stainless steel interior cabinet
Stainless steel front, sides and top exterior
Stainless steel interior side racks
Stainless steel frame, side hinged door
5mm thick door glass
Stainless steel control panel
Aluminised coated steel base and rear panels

CONTROLS

5.7" LED backlit touch screen
Icon driven menu
BMP image icon imports via USB port
Program updates via USB port
Individual shelf timers
Temperature range 20- 90°C

CLEANING

Stainless steel top and side exterior panels
Removable plug-in oven door seal (no tools required)

SPECIFICATIONS

Electrical Requirements

220-240V, 50Hz, 1-phase, 2.05kW, 8.5A

220-240V, 60hz, 1 phase, 2.05kW, 8.5A

13A cordset fitted

External Dimensions

Width 735mm

Height 1015mm including dia. 76mm castors

Depth 810mm

Nett Weight

88kg

Packing Data

107kg

0.97m³

Width 780mm

Height 1295mm

Depth 960mm

INSTALLATION CLEARANCES

Rear 25mm

LH Side 0mm

RH Side 0mm

CLEARANCE FROM SOURCES OF HEAT

A minimum distance of 300mm from the appliance sides is required

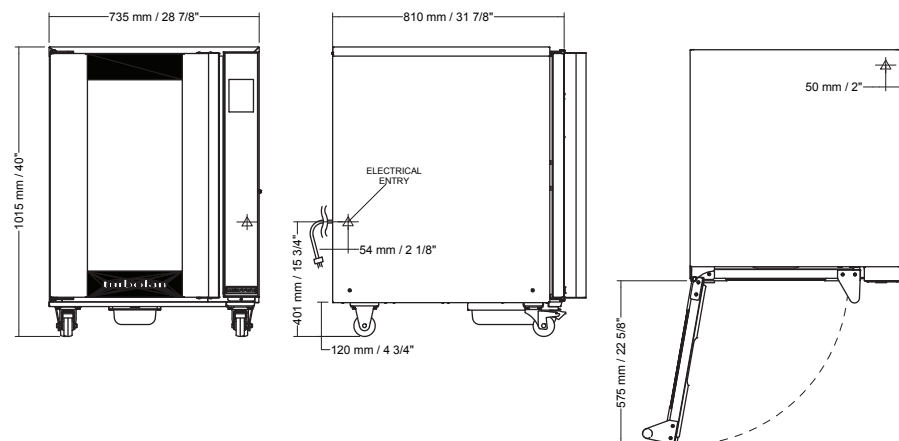

blue-seal.co.uk
turbofanoven.com

United Kingdom
Blue Seal Limited

Unit 67
Gravelly Business Park
Gravelly
Birmingham B24 8TQ
England
Telephone 0121-327 5575
Facsimile 0121-327 9711
sales@blue-seal.co.uk
www.blue-seal.co.uk

Australia
Moffat Pty Limited

740 Springvale Road
Mulgrave, Victoria 3170
Australia
Telephone 03-9518 3888
Facsimile 03-9518 3833
vsales@moffat.com.au
www.moffat.com.au

New Zealand
Moffat Limited

Christchurch
45 Illinois Drive
Izone Business Hub
Rolleston 7675
Telephone +64 3-983 6600
Facsimile +64 3-983 6660
sales@moffat.co.nz
www.moffat.co.nz



ISO9001
Quality
Management
Standard

Designed and manufactured by



ISO9001

All Turbofan products are designed and manufactured by Moffat using the internationally recognised ISO9001 quality management system, covering design, manufacture and final inspection, ensuring consistent high quality at all times.

In line with policy to continually develop and improve its products, Moffat Limited reserves the right to change specifications and design without notice.



© Copyright Moffat Ltd
UK.TFN.S.1601

