

Technical data sheet for

## H10T HOLDING CABINET - HALF SIZE

10 Tray Electric Holding Cabinet TOUCH SCREEN CONTROL



### STANDARD FEATURES

- Designed for individual use or system installed with Turbofan E33T Convection Ovens
- 10 Half size sheet pan capacity
- 10 12" x 20" steam pan capacity
- 27/8" / 74mm tray spacing
- Compact 24" / 610mm width
- 110-120V plug-in 15A NEMA 5-15P cordset fitted
- 1200W cabinet heating
- Full double skin construction
- Touch Screen Control
- Icon driven program menu
- Individual shelf timers
- USB port for program/icon updating
- Electronic temperature control
- Continuous door seal
- Low velocity circulation fan system
- Dual halogen cabinet interior lamps
- Cabinet drain to condensate pan
- 4 dia. 3" / 76mm castors with 2 front castors with wheel and swivel lock, 2 rigid rear castors
- 100% recyclable packaging



### H10T

Unit shall be a Blue Seal electrically heated Turbofan Holding Cabinet. E.T.L listed and NSF.4 listed. The holding cabinet shall have double skin construction with stainless steel interior and exterior sides, front and top. Door shall be side hinged. Unit shall have capacity for 10 half size sheet pans or 10 12" x 20" steam pans. A single speed fan shall gently and evenly circulate air around the cabinet. Cabinet shall be controlled by a 5.7" Touch Screen control with individual shelf timers and cabinet temperature control. Holding cabinet shall be mounted on castors, with two rigid castors at rear and two castors, swivel and wheel lock at front. Holding Cabinet shall operate independently or in conjunction with Blue Seal Turbofan E33T Convection Oven. Holding Cabinet shall be fitted with a NEMA 5-15P cordset. Unit shall be supplied in 100% recyclable shipping packaging.

### H10T 10 Tray Electric Half Size Holding Cabinet TOUCH SCREEN CONTROL

#### CONSTRUCTION

304 stainless steel interior cabinet  
Stainless steel front, sides and top exterior  
Stainless steel interior side racks  
Stainless steel frame, side hinged door  
0.2"/5mm thick door glass  
Stainless steel control panel  
Aluminised coated steel rear panels  
Stainless steel base

#### CONTROLS

5.7" LED backlit touch screen  
Icon driven menu  
BMP image icon imports via USB port  
Program updates via USB port  
Individual shelf timers  
Temperature range 68-194°F / 20- 90°C

#### CLEANING

Stainless steel top and side exterior panels  
Removable plug-in oven door seal (no tools required)

#### SPECIFICATIONS

Electrical Requirements  
110-120V, 50/60Hz, 1-phase, 1.3kW, 10.4A  
NEMA 5-15P cordset fitted

#### External Dimensions

Width 24" / 610mm  
Height 40" / 1015mm including dia. 3" / 76mm castors  
Depth 26<sup>3</sup>/<sub>4</sub>" / 680mm

#### Nett Weight

171 lbs / 77.5kg

#### Packing Data

210lbs / 95.3kg  
22.6 ft<sup>3</sup> / 0.64m<sup>3</sup>  
Width 25<sup>3</sup>/<sub>4</sub>" / 655mm  
Height 46<sup>1</sup>/<sub>2</sub>" / 1180mm  
Depth 32<sup>5</sup>/<sub>8</sub>" / 830mm

#### INSTALLATION CLEARANCES

Rear 1" / 25mm  
LH Side 0" / 0mm  
RH Side 0" / 0mm

#### CLEARANCE FROM SOURCES OF HEAT

A minimum distance of 12" / 300mm from the appliance sides is required



www.blue-seal.ca  
www.turbofanoven.com  
www.servecanada.com

#### CANADA

Serve Canada  
40 East Pearce Street  
Richmond Hill ON  
L4B 1B7  
Ph Toll Free 800-263-1455  
Fax 905-731-7687  
Email info@servecanada.com

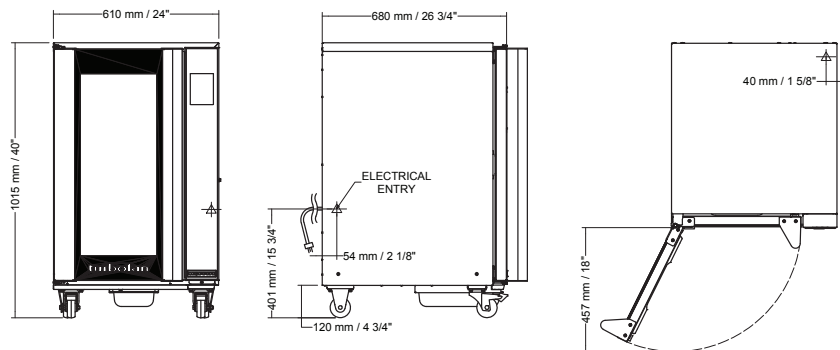

Manufactured by:  
Moffat Limited  
45 Illinois Drive, Izone Business Hub  
Rolleston 7675, New Zealand



ISO9001  
Quality  
Management  
Standard

Designed and manufactured by



#### ISO9001

All Turbofan products are designed and manufactured by Moffat using the internationally recognised ISO9001 quality management system, covering design, manufacture and final inspection, ensuring consistent high quality at all times.

In line with policy to continually develop and improve its products, Moffat Limited reserves the right to change specifications and design without notice.

© Copyright Moffat Ltd  
CA.TFN.S.1701



an Ali Group Company



The Spirit of Excellence