

Technical data sheet for

## H8D-UC HOLDING CABINET - 1/1 GN

8 Tray Electric Under-counter Holding Cabinet DIGITAL CONTROL



### STANDARD FEATURES

- Under-counter 810mm unit height
- Designed for individual use or system installed with Turbofan E33D Convection Ovens
- 8 1/1 GN pan capacity
- 74mm tray spacing
- Compact 610mm width
- 220-240V plug-in 10A cordset fitted
- 1200W cabinet heating
- Full double skin construction
- Digital display Temperature and Timer controls
- Large easy view 20mm high displays
- Electronic temperature control
- 3 hold timers
- Continuous door seal
- Low velocity circulation fan system
- Dual halogen cabinet interior lamps
- Cabinet drain to condensate pan
- 4 dia. 65mm castors with 2 front castors with wheel and swivel lock, 2 rigid rear castors
- 100% recyclable packaging



### H8D-UC

Unit shall be a Moffat electrically heated Turbofan Under-counter Holding Cabinet. NSF.4 listed. The holding cabinet shall have double skin construction with stainless steel interior and exterior sides, front and top. Door shall be side hinged. Unit shall have capacity for 8 1/1 GN pans. A single speed fan shall gently and evenly circulate air around the cabinet. Cabinet shall be controlled by a Digital display electronic Temperature and Timer controller. 3 hold timers shall be standard. Holding cabinet shall be mounted on castors, with two rigid castors at rear and two castors, swivel and wheel lock at front. Holding Cabinet shall be fitted with a 10A cordset. Unit shall be supplied in 100% recyclable shipping packaging.

### H8D-UC 8 Tray Electric 1/1 GN Size Under-counter Holding Cabinet DIGITAL CONTROL

#### CONSTRUCTION

304 stainless steel interior cabinet  
Stainless steel front, sides and top exterior  
Stainless steel interior side racks  
Stainless steel frame, side hinged door  
5mm thick door glass  
Stainless steel control panel  
Aluminised coated steel base and rear panels

#### CONTROLS

Electronic controls with Digital Time and Temperature displays  
Large 20mm high LED displays  
ON/OFF key  
Cabinet lamp key  
Temperature set and actual key  
3 timer keys  
Timer range up to 4 hours  
Timers countdown or count-up modes  
Temperature range 20- 90°C

#### CLEANING

Stainless steel top and side exterior panels  
Removable plug-in oven door seal (no tools required)

#### SPECIFICATIONS

Electrical Requirements  
220-240V, 50Hz, 1-phase, 1.3kW, 5.4A  
220-240V, 60Hz, 1-phase, 1.3kW, 5.4A  
10A cordset fitted

#### External Dimensions

Width 610mm  
Height 810mm including dia. 65mm castors  
Depth 680mm

#### Nett Weight

65kg

#### Packing Data

82.8kg  
0.53m<sup>3</sup>  
Width 655mm  
Height 975mm  
Depth 830mm

#### INSTALLATION CLEARANCES

Rear 25mm  
LH Side 0mm  
RH Side 0mm

#### CLEARANCE FROM SOURCES OF HEAT

A minimum distance of 300mm from the appliance sides is required

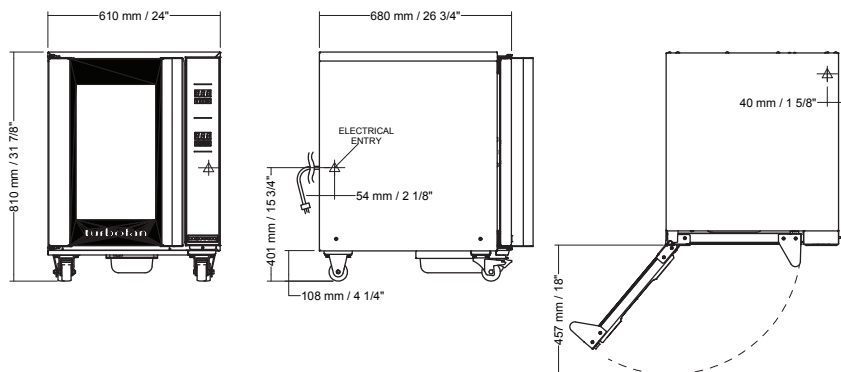

Australia  
www.moffat.com.au  
New Zealand  
www.moffat.co.nz  
www.turbofanoven.com

Australia  
Moffat Pty Limited

Victoria/Tasmania  
740 Springvale Road  
Mulgrave, Victoria 3170  
Telephone 03-9518 3888  
Facsimile 03-9518 3833  
vsales@moffat.com.au

New South Wales  
Telephone 02-8833 4111  
nswsales@moffat.com.au

South Australia  
Telephone 03-9518 3888  
vsales@moffat.com.au

Queensland  
Telephone 07-3630 8600  
qldsales@moffat.com.au

Western Australia  
Telephone 08-9202 6820  
bgarcia@moffat.com.au

New Zealand  
Moffat Limited

Christchurch  
45 Illinois Drive  
Izone Business Hub  
Rolleston 7675  
Telephone +64 3-983 6600  
Facsimile +64 3-983 6660  
sales@moffat.co.nz

Auckland  
Telephone 09-574 3150  
sales@moffat.co.nz



ISO9001  
Quality  
Management  
Standard

Designed and manufactured by



ISO9001

All Turbofan products are designed and manufactured by Moffat using the internationally recognised ISO9001 quality management system, covering design, manufacture and final inspection, ensuring consistent high quality at all times.

In line with policy to continually develop and improve its products, Moffat Limited reserves the right to change specifications and design without notice.



© Copyright Moffat Ltd  
AN.TFN.S.1601